

Investigation of the External Loads Applied on the PVC and PE Pressurized Pipes

Lect. Humam Mohammed Salih

humsalih@gmail.com

University of Technology - Mechanical Engineering
Department

Humam Kareem Jalghef

humam.karem@yahoo.com

University of Technology - Mechanical Engineering
Department

Abstract: *The irrigation systems, water supply system, sewage water systemetc. Dealing with many types of pipes and fittings depending on the applications. The current study was concert on test the polyethylene (PE) and polyvinyl chloride (PVC) pipes experimentally and theoretically under external loads and internal pressure to simulate the application conditions of pipes which are buried under ground used to transit the fluid under pressure such as drink water, sewage water or any other purpose and find out the deformation, stress and strain due to this loads. The tested was carried out for two size (actual and standard) of the two pipes (PE and PVC). The external load represented by a force in range (10-50KN), and the internal loads represented in pressure in range (5-20 bar). In the experiment a hydraulic press was used to supply the external load and hydraulic pump to supply the internal pressure with two adapter on the two end of tested pipe. The results showed*

that the deformation, stress and strain increase with increase in internal and external loads and the peak values of that were in the maximum internal and external loads (20 bar internal pressure and 50KN external force), also the experimental tests match the numerical calculation for both actual and standard size.

Keywords: polyvinyl chloride pipes, polyethylene pipes, the pipes under pressure.

1. Introduction

In Iraq, the selection of these types of pipes proceeds by the supplier of these systems according to their recommendations. Sometimes these recommendations is according to the international standards some time is not. Therefor this paper dealing with the most important properties suitable for the Iraqi recommendations and ambient conditions. Two types of pipe are investigated PVC and PE. The investigation was carried out theoretically and practically, external load and internal pressure were applied simultaneously. The internal pressure represented the pressure produce from the flow of fluid inside the pipe, while the external loads represented any effect forces on the pipes along the lifetime of the pipe such as thickness of barring layer.

In the twentieth century great development on PVC and PE pipe were employed. In the mid-1930s, German scientists and engineers developed and produced limited quantities of PVC pipe. Some PVC pipe installed at that time continues to provide satisfactory service today. Molecularly oriented polyvinyl chloride (PVC) pressure pipe has been installed in Europe since the early 1970s and in North America since 1991, [1].

The properties of many polymers are significantly influenced by the exposure to the environment. In many weathering condition was very drawback effect on the material, which cause to less the age of the component or make it under worse performance.

PVC is one of the most important vinyl polymers that produced from petroleum (derivatives). It's production coming as second class after Polyethylene (PE) in the world. There are two important kinds of PVC:

1. Rigid PVC which is used in fabrication of pipes and plastic plates (sheets).
2. Flexible PVC, which is composed from polymer with addition of plasticizers.

Despite its enormously technical and economic importance, PVC still possesses many problems such as low thermal stability and brittleness, but it is suitable for many field applications like electrical trenches because of high electrical insulation, high resistance for abrasion, low diffusion for humidity, good flexibility within range of temperatures, resistance to water, bases, acids, alcohols, oils, and aliphatic hydrocarbon components (compounds), [2].

While high and low density-engineering plastic pipes (polyethylene) are one of the most important developing aims for the pipe industry presently. It has been applied to transport the water, gas, and corrosive liquid because of its low price, easily installed and good corrosive resistance. It was found that one of the failure modes of PE pipe is the crack slowly grows across the thick direction and leads to failure at last. The crack initiation period depends on material properties, Fangjuan, 2004, Design of a PE piping system is essentially no different from the design undertaken with any ductile and flexible piping material [3]. Fangjuan, investigation the fracture properties of high-density Polyethylene (HDPE) pipe, the study Investigation shows that one of the failure modes of HDPE pipe is the crack slowly grows across the thick direction and leads to failure at last, so that it is very important to study the resistance to crack initiation of HDPE pipe and its butt-fusion welded joint [4]. Hashem, 1999, study the elastic-plastic behavior and limit load analysis of pipe bends under out-of-plane moment loading and internal pressure. The results of these analyses are presented in the form of load-deflection plots, for each load

case belonging to each model. From the load-deflection curves, the limit moments of each case are obtained. The limit loads are then compared to those computed using some of the analytical and empirical equations available in the literature. The effects of modeling parameters are also studied. The results obtained from small displacement and large-displacement analyses are compared, and the effect of using a strain-hardening material model is also investigated. Ollick and Al-Amri, 2003, study the weathering effects on mechanical properties of low and high-density polyethylene pipes used in irrigation networks. The obtained results showed that, the exposure to outdoor weathering conditions for periods equal to or less than 8 years increased the yield stress while it decreased for exposure periods more than 8 years. In this paper a numerical and experimental investigation were carried out to establish a new idea for the general and private Iraqi sectors when selection of pipes for different applications. Also to optimize the quality with regards to prices [5].

2. Numerical Investigation And Experimental Setup

2.1. Numerical Investigation:

Use the ANSYS Workbench Simulation module to define the current model's environmental loading conditions (external load and internal pressure), solve the simulation, and review results in various formats depending on the type of simulation.

In this part a structural analysis for the tested PVC & PE pipe under two conditions: standard and actual conditions (where the standard represented the geometry with standard dimension while the actual represented the geometry with actual dimension) by using ANSYS 15 (Workbench).

2.1.1. Step of Simulation

The step on the present simulate can be represented in the following step:

1. Geometry : In this step the pipe geometry was created by ANSYS designed modular where the pipe dimension was :
 - a. For UPVC pipes the standard specification: (Diameter $D=250$ mm, Thickness $t= 11.9$ mm and Length $L= 375$ mm), and actual dimension: (Diameter $D=249.78$ mm, Thickness $t= 11.76$ mm and Length $L= 375$ mm).
 - b. For PE pipes the standard specification: (Diameter $D=250$ mm, Thickness $t= 14.8$ mm and Length $L= 375$ mm), and actual dimension: (Diameter $D=251.25$ mm, Thickness $t= 14.6$ mm and Length $L= 375$ mm).
2. Mesh: To obtained best accurate result the geometry must be divided into small size element and this done by applied the suite type mesh which was available in the ANSYS workbench mesh type and also under this categories can be controlled in the size of element to reach to the accurate resolution which measured by the total number of element . For the current work the type of mesh was curvature mesh and the total number of element was (1.2) million elements.
3. Setup: In this step, the boundary applied on the pipe geometry. Where the boundary was fixed the pipe from the two ends and applied pressure on the internal surface, This applied pressure was over range (5-20 bar) divided into six steps and the external load was represented in applied force in magnitude (10-50 kN) divided into three steps, for the standard and actual conditions as shown in Figure.1.
4. Solution: After adjusting boundary conditions were the case is resolved to give it a solution (solve) then the solution will be for the unknowns to be computed which is displacement resulting from the applied loads on the body.
5. Final step (ANSYS results): The deformation, normal stress and normal strain presented after each run of different case. Figure

(4. a,b,c) represents a sample of the tested cases. While the results at different applied loads of the other tested cases were taken in comparison for both standard and actual conditions.

The procedure of numerical testing was performed in two categories: The first one fixing the external load with variable internal pressure and the second one is fixing the internal pressure with variable external load.

2.2. Experimental Setup:

The experimental work was performed by using a (10 Ton) hydraulic press with variable load to insure different applied external loads. The internal pressure applied using a manual pump, which can insure a pressure up to 60 bar, Special adapters and fittings designed and produced to achieve exact sealing and maintain the pressure during the test, Figure.2 show the experimental rig.

The sample pipes are a 249.78 mm in diameter and 11.76 mm in thickness and 1.5 D in length. This sample satisfy the standard values recommended by **DIN 8062 and ASTM D-1785 schedule 80 class 4 for UPVC (6)**. The other sample is PE of high density with 251.25mm in diameter and 14.6 mm in thickness and 1.5 D in length which satisfy the standard values recommended by **DIN 8074 and ISO4427 this sample is from the category SDR17 PN10 (7)**.

2.3. Test Procedure:

The test of all sample was carried on by:

- a. Applying a range of three step external load varying from (10-50 KN) a combined with different internal pressure.
- b. A five steps range (5-20 bar) of pressure applied on pipes under test, while observing of the pipe under these conditions and configure the shape of deformation and the value of stress and

strain. Pre pressurizing of pipe under test from the range of (5-20) in six steps, an external load applied in each step until the shape of pipe starts changed note that each sample tested without internal pressure also to configure the shape of deformation as shown in Figure.3

3. Results And Discussion:

The following sample of results shows the total deformation, normal stress and normal strain for the actual and standard geometries. The value of these parameters can used to note the total deformation in the pipes due to internal and external loads according to the procedure mentioned above. Different numerical runs applied for different sizes of pipes (actual measured size and standard pipes size according to DIN, ISO Standard).

The results of these runs presented bellow for two different pipes material (PE and PVC).

Figure. (5 a and b) shows the numerical results of deformation, stress and strain for PE pipe, we can be noted that the behavior of pipe under loaded was response extrusive with increase in the internal and external loads. For the numerical results of pipe under external force (10-50KN) in three steps, and the range of internal applied pressure (5-20 bar) in six step, the values of deformation in millimeters under external force (10KN) was in range (0.85 to 2.62), under external force (30KN) was in range (1.39 to 3.12), and under external force (50KN) was in range (1.94 to 3.67), the values of stress in MPa under external force (10KN) was in range (10.1 to 36.9), under external force (30KN) was (12.3 to 39.16), and under external force (50KN) was (14.53 to 41.39). And the values of strain under force (10KN) was in range (0.005 to 0.0194), under external force (30KN) was in range (0.0055 to 0.0199) and under external force (50 KN) was in range (0.0061 to 0.0204), those results was to the actual PE pipe size, and for its standard size the deformation, stress and strain were the same behavior of actual size the different only in the values, those values was for the deformation under external force (10KN) was in range (0.84 to

2.59), under external force (30KN) was in range (1.38 to 3), and under external force (50KN) was in range (1.92 to 3.65). And the values of stress in MPa under external force (10KN) was in range (9.99 to 36.7), under external force (30KN) was in range (12.2 to 38.8), and under external force (50KN) was in range (14.4 to 41.06). And the values of strain under external force (10KN) was in range (0.0050 to 0.0192) and under external force (30KN) was in range (0.0055 to 0.0197) and under external force (50 KN) was in range (0.0060 to 0.0202).

Figure.7 shows the experimental results for actual size were very approximate from the numerical results those value for deformation was in range (0. 87 to 3.1) under external force (10KN), was in range (1.64 to 3.8) under external force (30KN) and was in range (2.25 to 0.00439) under external force (50KN), stress was in range (11.1 to 37.1) under eternal force (10KN), was in range (12.9 to 39.9) under eternal force (30KN), and was in range (14.9 to 42.3) under external force (50KN), and strain was in range (0.0052 to 0.021) under eternal force (10KN), was in range (0.0058 to 0.023) under external force (30KN), and was in range (0.0066 to 0.024) under eternal force (50KN).

From figures it can be noted that for a numerical the minimum actual size deformation at force 10KN and pressure 5 bar with value 0.85 and the maximum value was at force 50KN and pressure 20 bar which value 3.67, and the difference between the two value equal to 2.82, the minimum stress was at force 10KN and pressure 5 bar with value 10.1 and the maximum value was at force 50KN and pressure 20 bar which value 36.9, and the difference between the two value equal to 26.8, and the minimum strain was at force 10KN and pressure 5 bar with value 0.005 and the maximum value was at force 50KN and pressure 20 bar which value 0.0194, and the difference between the two value equal to 0.0144.

The difference of minimum and maximum values for deformation, stress and strain between experimental and numerical actual size were for deformation (0.02 and 0. 72), stress (2.8 and 1.31) and strain (0.0002 and 0.0036), from that the numerical test

for any tested pipes is quite sufficient to judge the properties of any pipe depended on its applications. This increase in the deformation, stress and strain values can return it due to the increase in the external force if we regarded the internal pressure can supplied the supported to the pipe.

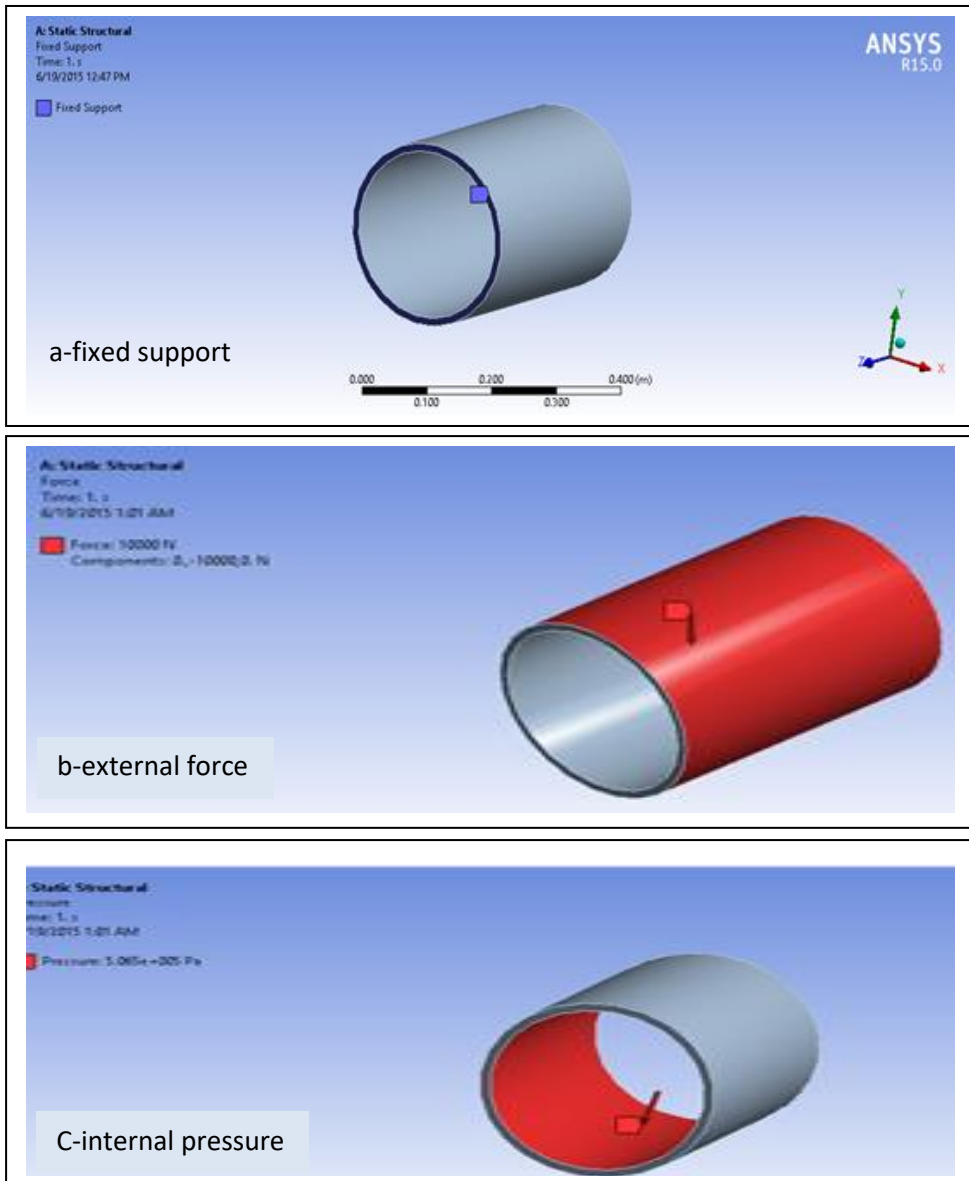

Figure 1: a,b,c. Boundary condition

The same behavior it can noted in the figures (7 and 8) for the numerical and experimental test for PVC pipe but the difference was in the values. The experimental result shows that pipes behaviors under internal pressure vary in accordance to increase of that pressure compared with empty pipe also a difference of (2-3%) in experimental result with results got applying ANSYS Workbench Software (Numerical work) and the reason returned to the difference in the material or found the bug in the construction of martial.

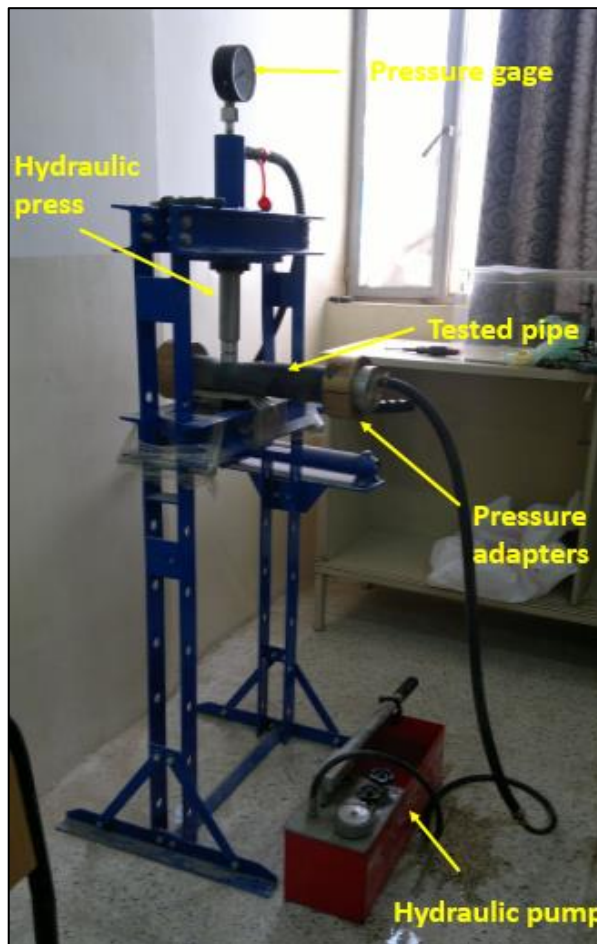

Figure 2: The tested rig



Figure 3: The pipe under tested

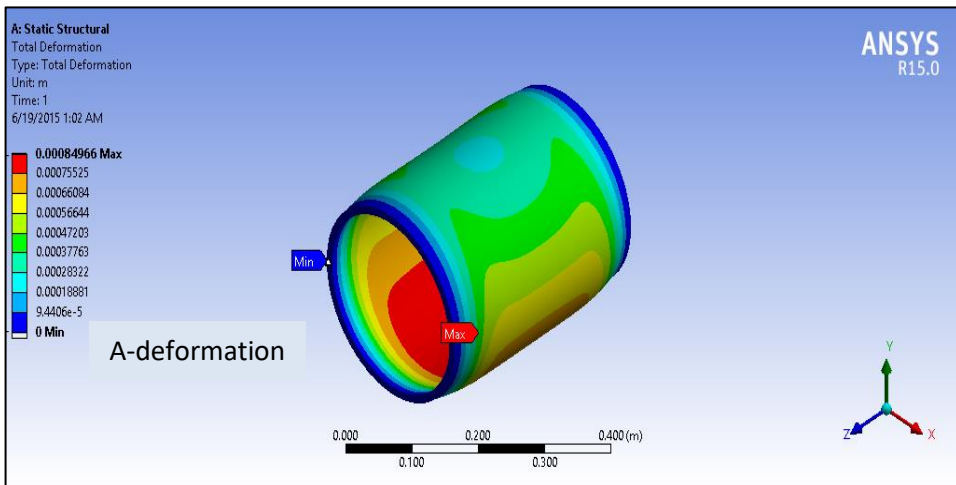

Figure 4: a deformation

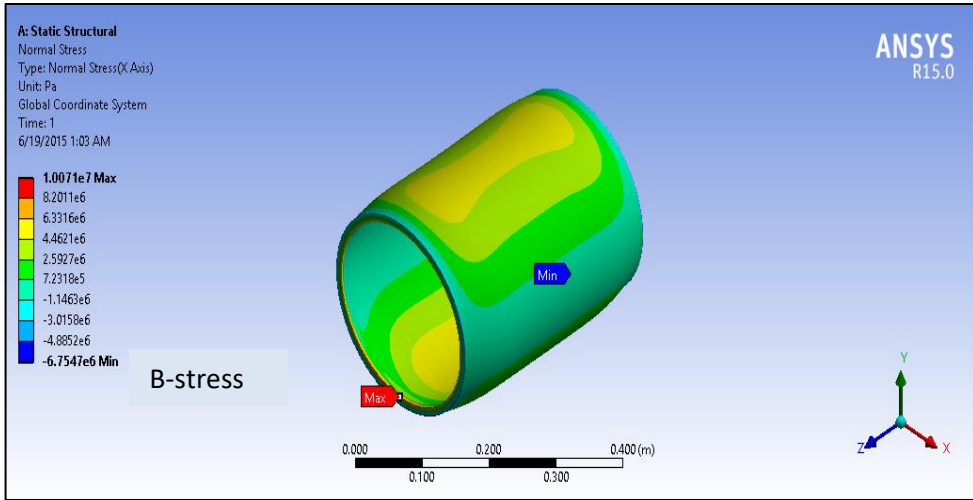

Figure 4: b stress

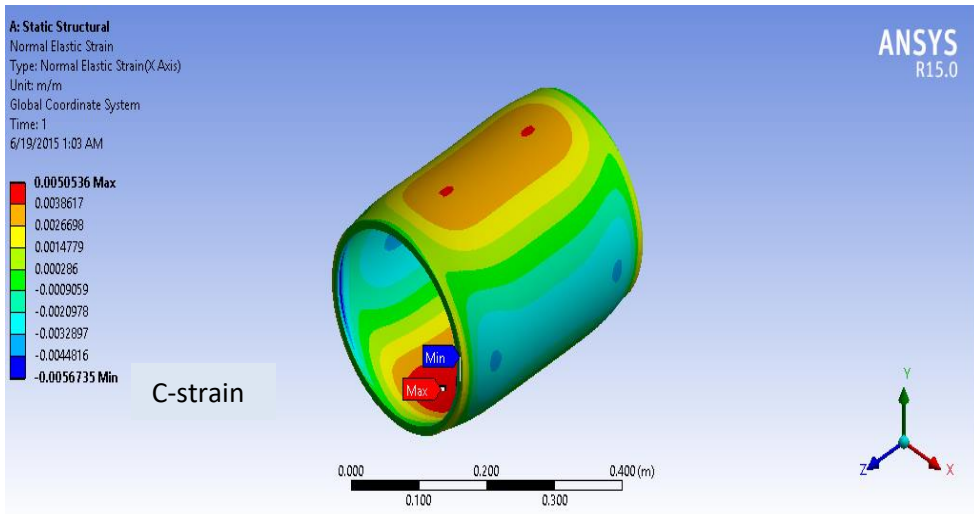

Figure 4: c strain

Figure 4: The sample of numerical tested result of deformation, stress and strain

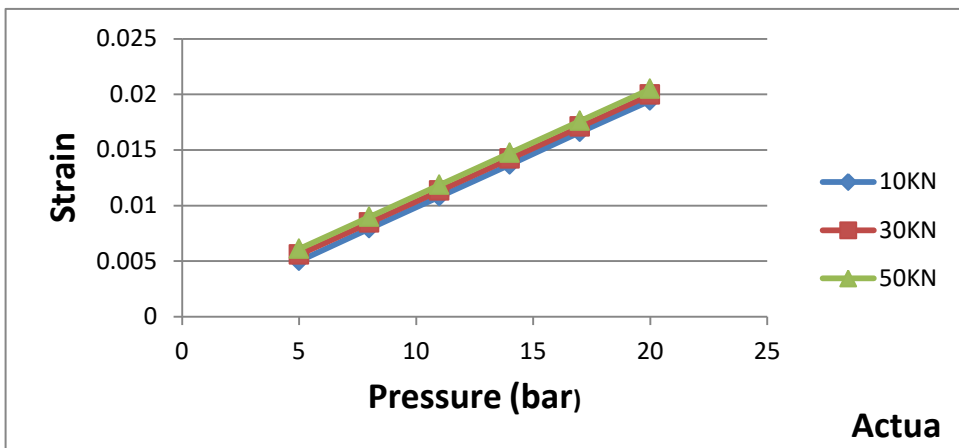
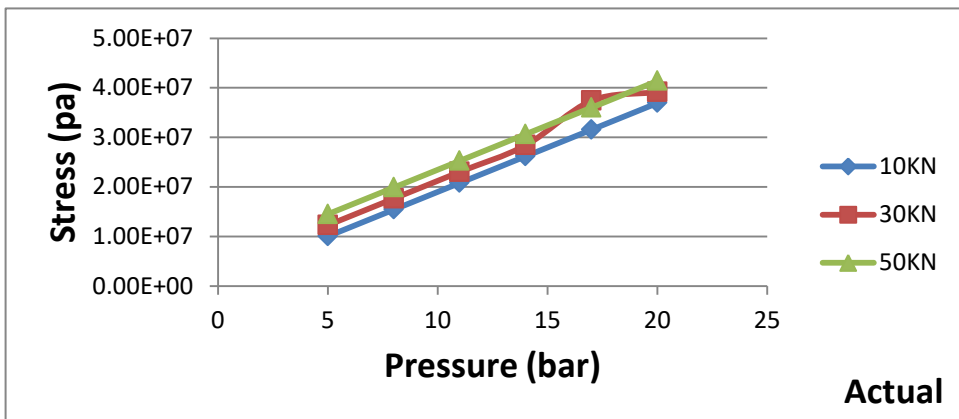
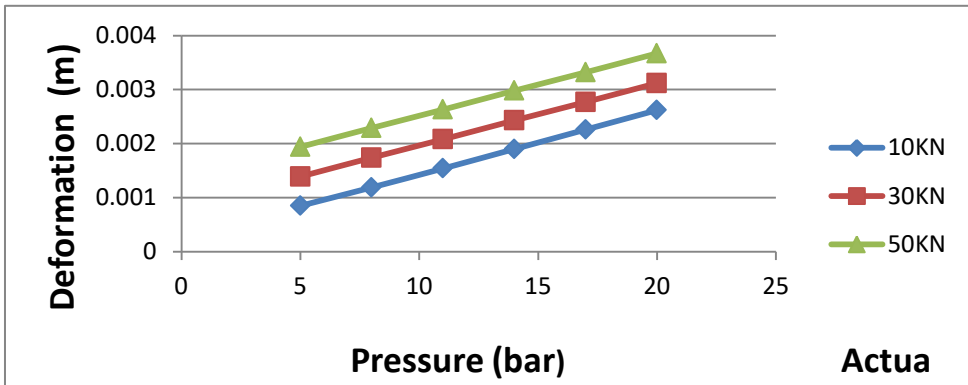

Figure 5a: Numerical results of deformation, stress and strain for actual size PE pipe

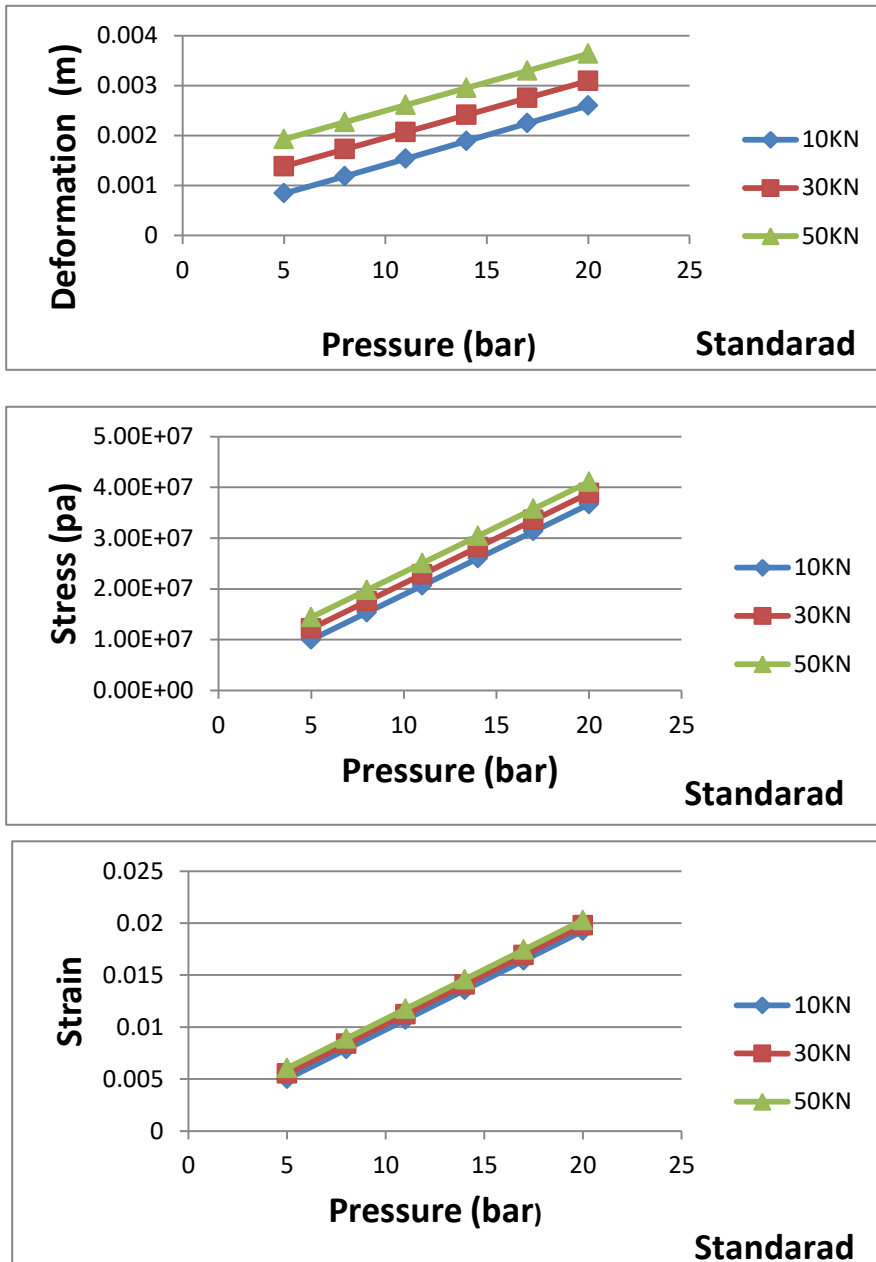

Figure 5b: Numerical results of deformation, stress and strain for standard PE pipe

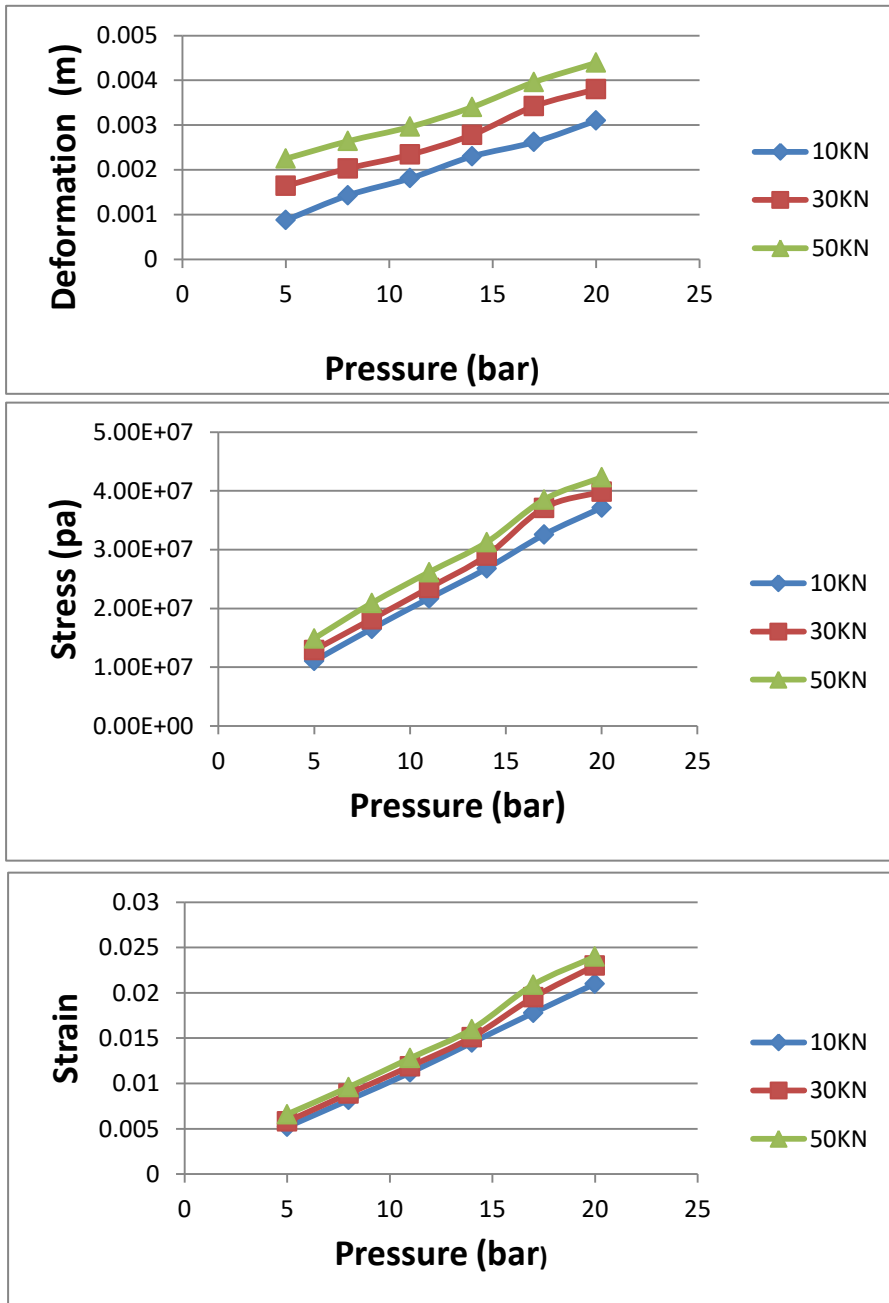

Figure 6: Experimental results of Deformation, Strain and Stress for PE pipe

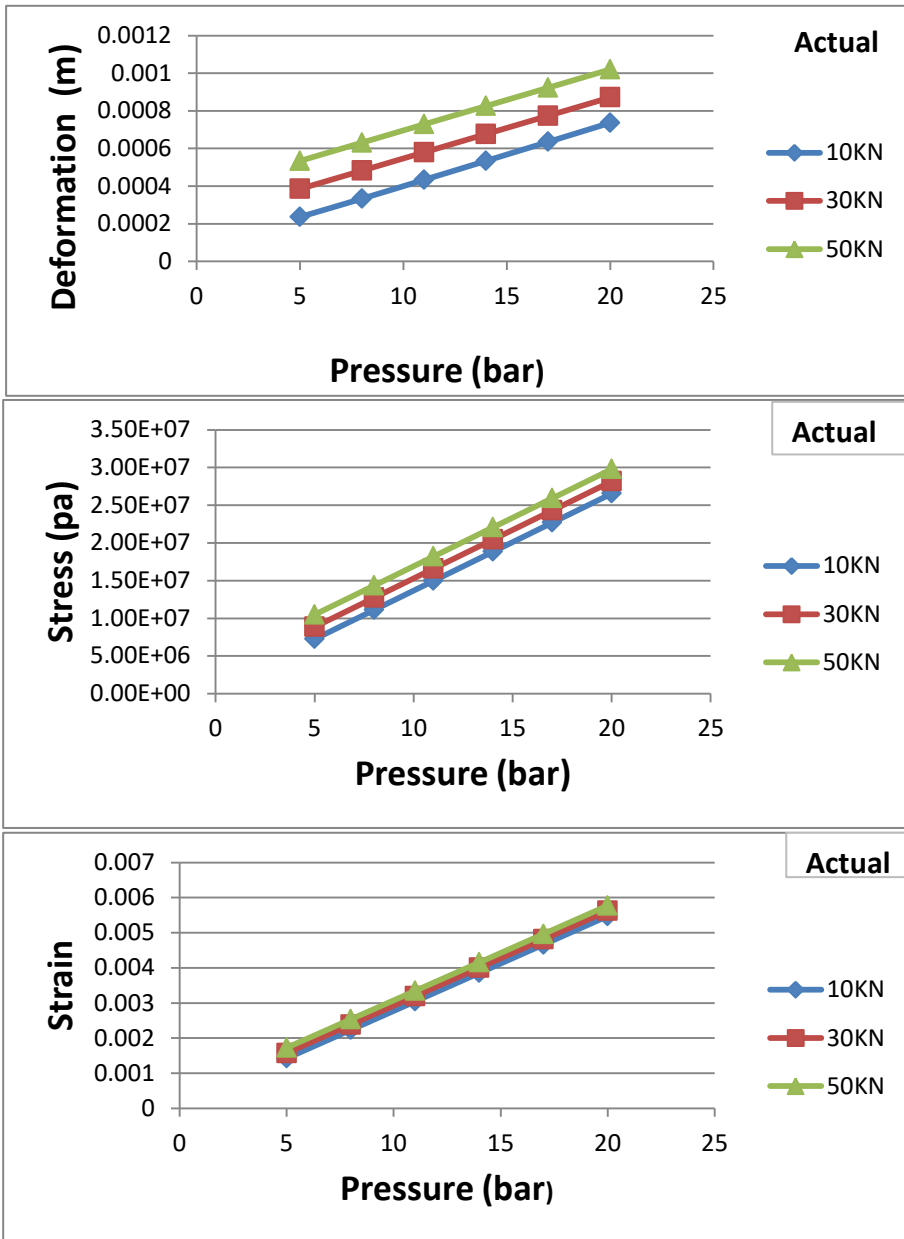

Figure 7a: Numerical results of deformation, stress and strain for actual PVC pipe

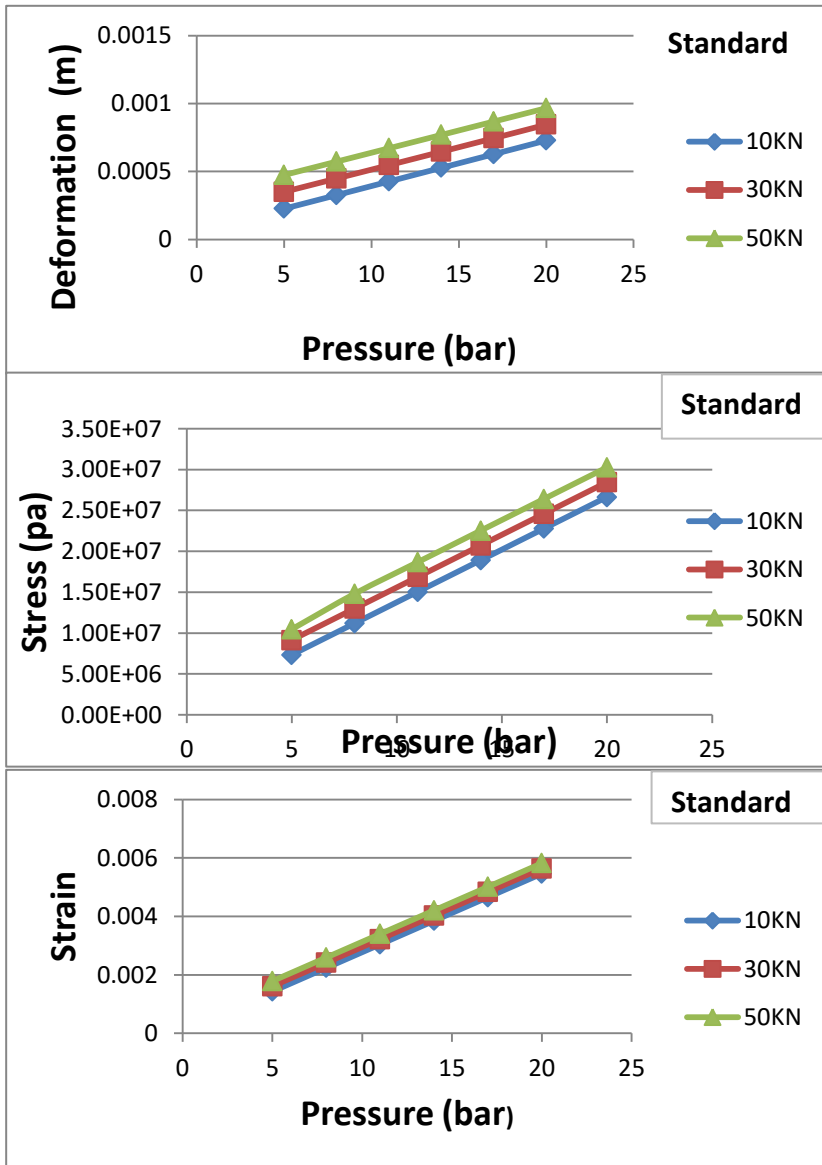

Figure 7b: Numerical results of deformation, stress and strain for Standard PVC pipe

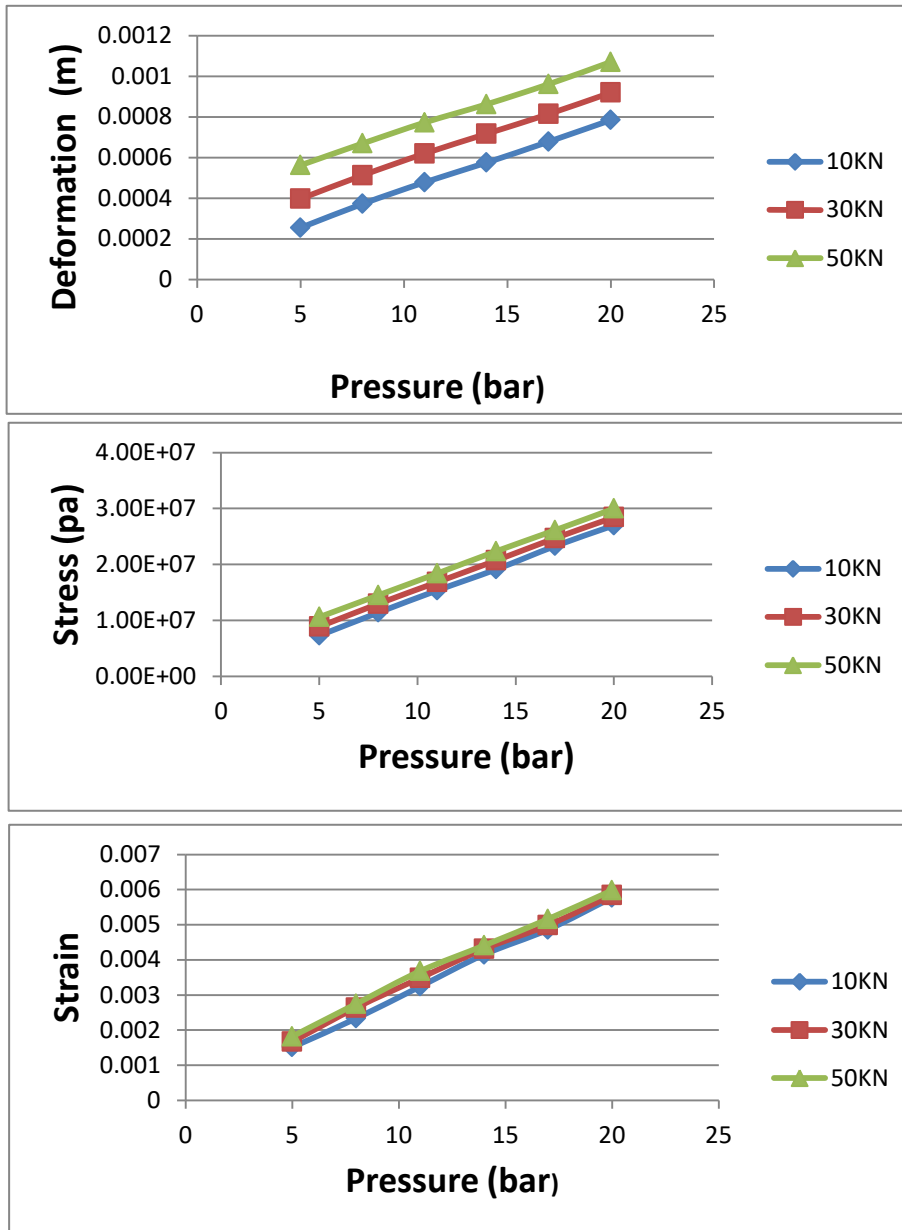

Figure 8: Experimental results of Deformation, Strain and Stress for PVC pipe

4. Conclusion

1. To get the best performance from the pipe must use the pipe under safety loads conditions. Also to keep the pipe from the failure under external load must don't work it without internal load (for the pipe that used in irrigation, water supply and such that application must be inline when subjected to the external loads).
2. Applied the internal loads pressure matching with external loads give the pipe stronger and keep it from early failure.
3. The difference between the numerical and experimental tested give closed convergence and for that we can used the numerical studies instead of the experimental studies in tested the pipes if they are from the same manufacturer.
4. The difference between the actual and standard size also give the convergence and this allow to the actual size in used without any drawback in that purposes.
5. From our experience in testing of dozens of pipe through the scientific and engineering Bureau University of Technology, the Iraqi institution which deals with use of PE & PVC pipes should take in consideration the actual need of pipe properties to achieve the optimum price and specifications.

References

- [1] AWWA, 2002, "PVC Pipe Design and installation. Manual M23", Second Edition. Copyright © 2002 American Water Works Association, All Rights Reserved
- [2] Awham M. H, and Zaid Ghanem M. Salih, September 2011, "A Study of some Mechanical Behavior on a Thermoplastic Material", Journal of Al-Nahrain University, Vol.14 (3), pp.58-65
- [3] Fangjuan Qi, Lixing Huo, Yufeng Zhang and Hongyang Jing, 2004, "Study on Fracture Properties of High-density

Polyethylene (HDPE) Pipe", Key Engineering Materials Vols. 261-263 pp 153-158.

- [4] Hashem M. M., 1999, "Elastic-Plastic behavior and limit load analysis of pipe bends under out of plane moment loading and internal pressure", The American University in Cairo School of Sciences and Engineering Department.
- [5] Ollick. A.M and Al-Amri, A.M, 2003, "Weathering effects on mechanical properties of low and high density polyethylene pipes used in irrigation networks", Agricultural Engineering Department, King Faisal University, Saudi Arabia Alexandria Engineering Journal, Vol. 42, No. 6, 659-667 659.
- [6] DIN 8062 and ASTM D-1785 schedule 80 class 4 for PVC.
- [7] DIN 8074 and ISO4427 SDR17 PN10.

التحقيق في الأحمال الخارجية المسلطة على أنابيب البولي فينيل كلورايد والبولي ايثيلين المضغوط

م. همام محمد صالح

humsalih@gmail.com

الجامعة التكنولوجية - قسم الهندسة الميكانيكية

م.م. همام كريم جلفج

humam.karem@yahoo.com

الجامعة التكنولوجية - قسم الهندسة الميكانيكية

المستخلص:

ركزت الدراسة الحالية على اختبار أنابيب البولي إيثيلين (PE) والبولي فينيل كلورايد (PVC) عمليا ونظريا" تحت الأحمال الخارجية والضغوط الداخلية لمحاكاة ظروف تطبيق الأنابيب التي دفنت تحت الأرض المستخدمة لنقل السائل تحت الضغط مثل مياه الشرب، مياه الصرف الصحي أو لأي غرض آخر، ومعرفة التشوه، الاجهاد والانفعال بسبب هذه الأحمال. وأجريت الاختبار لحجمين (الحقيقي والقياسي) لنوعين من الأنابيب (PE و PVC). الحمل الخارجي ممثلة بقوة على مدى (10-50 كيلونيوتن)، والأحمال الداخلية ممثلة في الضغط على مدى (5-20 بار). الاختبار العملي كان باستخدام كابس يستخدم لتزويد الحمل الخارجي ومضخة هيدروليكية لتجهيز الضغط الداخلي مع اثنين من السدادات على نهايتي انبوب الاختبار. وأظهرت النتائج أن التشوه، الاجهاد والانفعال يزداد مع الزيادة في الأحمال الداخلية والخارجية وبلغت القيم ذروتها عند أقصى حمل داخلي وخارجي (الضغط الداخلي 20 بار و القوة الخارجية 50 كيلو نيوتن). وكان هنالك تقارب بين الاختبارات العملية والنظرية وكذلك بين الحجم الحقيقي والقياسي لنفس الأنابيب .

الكلمات الرئيسية: انابيب لبولي فينيل كلورايد، أنابيب البولي إيثيلين، الانابيب تحت الضغط.